



Industrie Service

EU-TYPE EXAMINATION CERTIFICATE

According to Annex IV, Part A of 2014/33/EU Directive

Certificate No.: EU-BD 1018

Certification Body of the Notified Body: TÜV SÜD Industrie Service GmbH
Westendstr. 199
80686 Munich – Germany
Identification No. 0036

Certificate Holder: BODE Components GmbH
Eichsfelder Str. 29
40595 Düsseldorf – Germany

Manufacturer of the Test Sample: BODE Components GmbH
Eichsfelder Str. 29
40595 Düsseldorf – Germany
(Manufacturer of Serial Production - see Enclosure)

Product: Braking device acting on the suspension ropes, as a part of the protection device against over-speed for the car moving in upwards direction and braking element against unintended car movement

Type: SB 380

Directive: 2014/33/EU

Reference Standards: EN 81-20:2014
EN 81-50:2014
EN 81-1:1998+A3:2009
EN 81-2:1998+A3:2009

Test report: EU-BD 1018 of 2016-12-09

Outcome: The safety component conforms to the essential health and safety requirements of the mentioned Directive as long as the requirements of the annex of this certificate are kept.

Date of Issue: 2016-12-09

Achim Janocha
Certification Body "lifts and cranes"



Annex to the EU-Type Examination Certificate No. EU-BD 1018 of 2016-12-09



Industrie Service

1 Scope of application

1.1 Generally

1.1.1 Make and design of suspension ropes

Only steel wire ropes meeting the requirements for traction lifts are permitted.

1.1.2 Suspension ropes - number and diameter

The number of ropes permitted depends on the brake device's size. All suspension ropes must rest on the brake lining and being centred to the brake plate.

The permitted diameter of the suspension ropes depends on the required slipping of the ropes. During operation the suspension ropes must not abrade the brake linings.

1.1.3 Maximum tripping speed of the overspeed governor and maximum rated speed (speed of the suspension ropes equals the rated speed of the car)

Maximum tripping speed 7.0 m/s

Maximum rated speed 5.6 m/s

1.2 Functionalities

Using as a braking device - part of the protection device against overspeed for the car moving in upwards direction (acting upwards) and / or using as a braking element - part of the protection device against unintended car movement (acting upwards and downwards)

Permissible range of brake force 28005 – 44888 N

Assigned arrangement and design features

➤ Maximum closing time 200 ms

➤ Distance of rope pass slipping acc. owner manual

2 Terms and Conditions

2.1 Rope maintenance shall always comply with owner manual of manufacturer. At heavily greased ropes the brake force may be reduced by up to 30 % for example.

2.2 Above mentioned safety component represents only a part of the protection device against overspeed for the car moving in upwards direction and unintended car movement. Only in combination with a detecting and tripping component in accordance with the standard (also two different components possible), which must be subjected to an own type-examination, can the created system fulfill the requirements for a protection device.

If the overspeed governor's electrical safety device is actuated in the same way, irrespective of whether the car is travelling upwards or downwards (consequence: braking device also responds when the car is travelling downwards) and the lift travels with a rated speed of more than 1 m/s, the electrical safety device must respond at speeds clearly below (approx. 10 %) the speed at which the overspeed governor is triggered (for the safety gear).

If the braking device is triggered via an additional (second) electrical safety device of the overspeed governor, this device only has to be activated when the triggering speed of the overspeed governor is reached.

2.3 At the pressure to the brake plate is exercised by means of compressed air and not e.g. by means of pressure springs or weights, the following conditions must be met:

- The pressure reservoir must hold a pressure volume being sufficient to allow for at least three braking plate actuations at a minimum pressure of 5 bar and maximum possible lift without re-charging.
- The pressure reservoir (or at a central pressure supply unit) must not exceed 8 bar and must not fall below 6 bar. The pressure at the cylinder must be at least 5 bar. If the required pressures are fallen below (insufficient power to actuate the braking device at standstill condition and/or electrical power to operate the compressor) the lift must be stopped and kept in standstill condition.
- As the force transmission from the force generating element (pressure reservoir) to the brake plate is not positive mechanically the fail-safety of all elements involved in the transmission (pressure switch, magnetic valve, pressure pipe, cylinder) must be checked once per day by actuating the braking device at standstill condition. In case of failure (non drop-out of the magnetic valve,

**Annex to the EU-Type Examination Certificate
No. EU-BD 1018 of 2016-12-09**



Industrie Service

non-switching of the pressure switch, pressure at the cylinder falls below minimum pressure 5 bar, no movement of the brake plate) the lift has to remain in standstill condition.

- 2.4 The adjustment of the pressure switch has to be protected against unauthorised re-adjustment (e.g. by colour seal).
- 2.5 The energy supply to the magnetic valve must be directly interrupted by the speed governor's electrical safety device or two independently actuated operational elements being dependent on this safety device. In case no overspeed governor is installed interruption has to be made analogue.
- 2.6 Mass configuration of the lift installation with regard to the permissible braking forces to be construed in a way that comply with the valid values of deceleration according standard EN 81-20 based on safety function (e.g. deceleration of the empty car in up direction not more than $1g_n$).
- 2.7 Appropriate measures must ensure that it is evident in the machine room whether the braking device has responded in line with its intended use as a safety component (following failure of an item of operating equipment such as breakage of a gearing element or shaft) or whether the response was caused by other reasons (e. g. loss of power supply or reaction after every stop). It must also be evident how to proceed in emergency operation (moving the car through manual operation or return motion control) after the braking device has responded.
- Once the braking device has responded in the intended way as a safety component, it should never be possible to move the lift machine via the emergency electrical operation.
- 2.8 The installer of the complete lift must create an examination instruction to fulfil the overall concept of the protection device, add it to the lift documentation and provide any necessary tools or measuring devices, which allow a safe examination (e. g. with closed landing doors).
- 2.9 The identification drawing number 9 6 380 1000 (page 1 and 2) including stamp dated 2016-12-09 shall be included to the EU type-examination for the identification and information of the general construction and operation and distinctness of the approved type. The installation conditions and connection requirements (mechanic, pneumatic, electric) are presented or described in separate documents (owner manual).
- 2.10 The EU type-examination certificate may only be used in combination with the corresponding annex and enclosure (List of authorized manufacturer of the serial production). The enclosure will be updated immediately after any change by the certification holder.

3 Remarks

- 3.1 Due to the system, a pressure of minimum 5 and maximum 8 bar may be built up. The above mentioned brake forces therefore refer to an operational pressure of minimum 5 bar (28005 N) and maximum 8 bar (44888 N) exercised on the pressure cylinder, dry ropes and at „braked-in condition” (ropes run-in into an overall braking distance at the suspension ropes of ca. 1,00 m). In principal, the impact of the pressure and maintenance condition of the suspension ropes on the brake force has to be observed (brake force directly proportional to the pressure).
- 3.2 The EU type examination of the braking device / braking element only refers to the requirements regarding protection device. Examination of compliance with other requirements according standard, reduction of braking forces due to wear and operational tear of the suspension ropes, are not part of this type-examination.
- 3.3 This EU type-examination certificate was issued according to the following standards:
- EN 81-1:1998 + A3:2009 (D), Annex F.7 and F.8
 - EN 81-20:2014 (D), part 5.6.6.11 and part 5.6.7.13
 - EN 81-50:2014 (D), part 5.7 and 5.8

A revision of this EU type-examination certificate is inevitable in case of changes or additions of the above mentioned standards or of changes of state of the art.

**Enclosure to the EU Type-Examination Certificate
No. EU-BD 1018 of 2016-12-09**



Industrie Service

Authorised Manufacturer of Serial Production – Production Sites (valid from: 2016-12-09):

Company BODE Components GmbH
Address Eichsfelder Str. 29
40595 Düsseldorf – Germany

- END OF DOCUMENT -

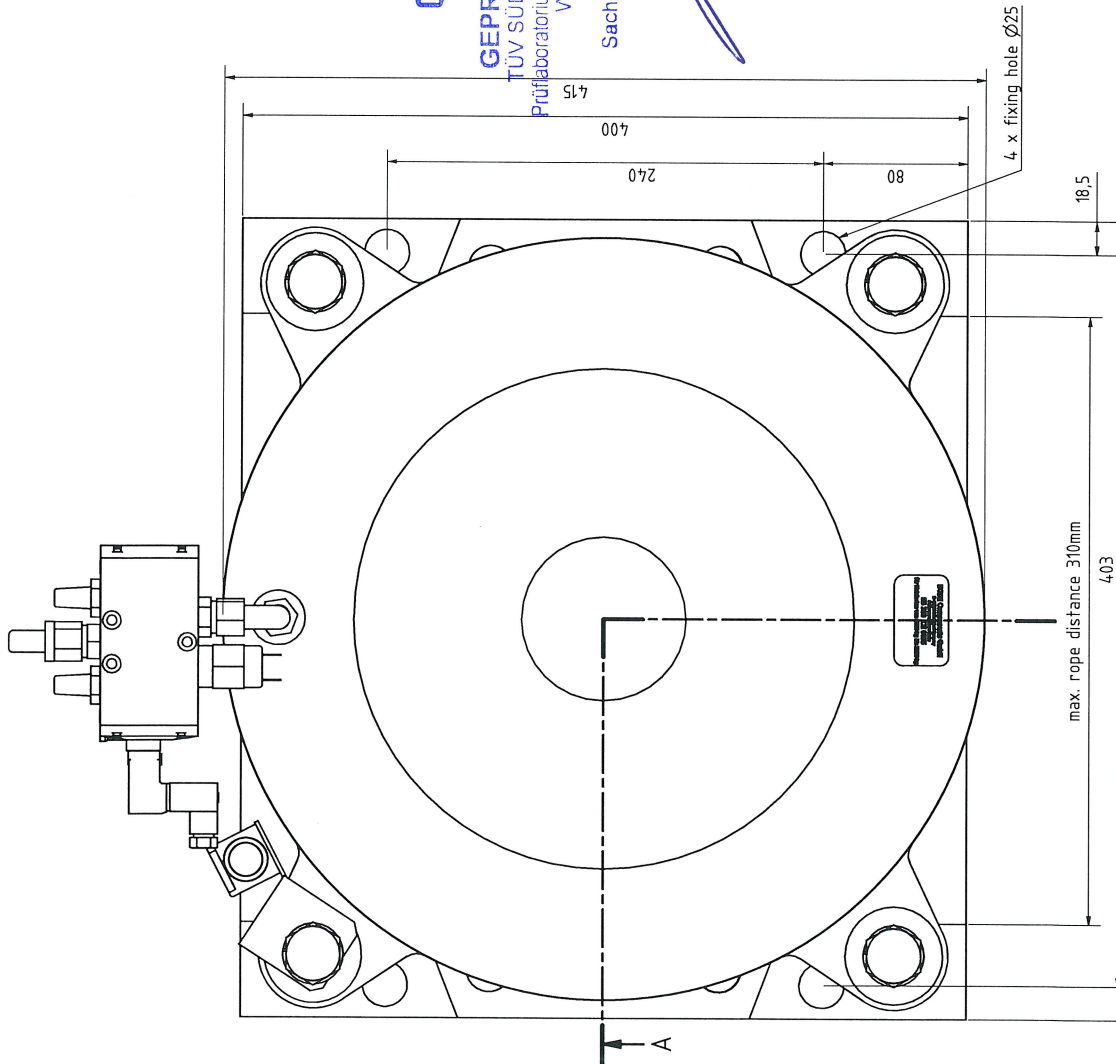

09. DEZ. 2016

GEPRÜFT / APPROVED
 TÜV SÜD Industrie Service GmbH
 Prüflaboratorium für Produkte der Fördertechnik
 Westendstraße 199
 80686 München
 Sachverständige(r) / Expert

475
 400
 240
 80
 4 x fixing hole $\varnothing 25$
 18,5
 max. rope distance 310mm
 403
 440

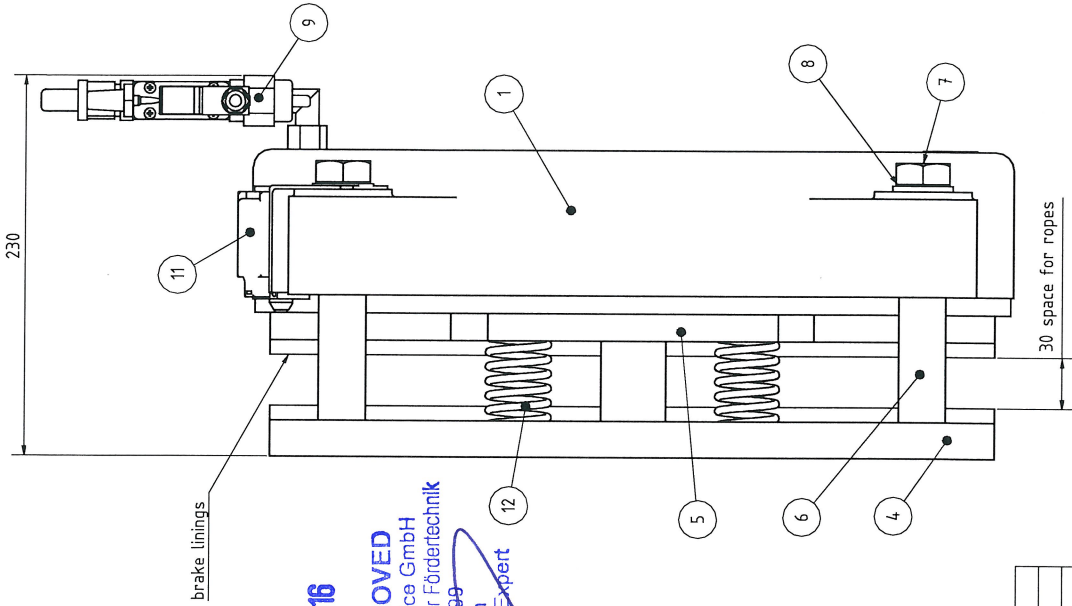

Object	Qty	Description
1	1	cylinder
2	1	piston
3	1	grooved ring
4	1	fixed brake pad
5	1	loose brake pad
6	4	distance tube
7	4	hex-head screw
8	4	lock washer
9	1	magnetic valve
11	1	switch
12	4	pressure spring

BODE Components		BODE Components	
Name	Material	Name	Material
Düsseldorf	Rope Brake SB 380	Düsseldorf	Rope Brake SB 380
	EU-BD 1018		EU-BD 1018
	braking force 28.005N - 44.888N		braking force 28.005N - 44.888N
	max. rope speed 7m/s		max. rope speed 7m/s
	9 6 380 1000		9 6 380 1000
	Blatt: 1		Blatt: 1

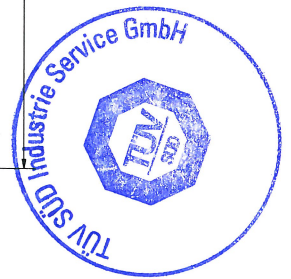



A-A (1 : 2)

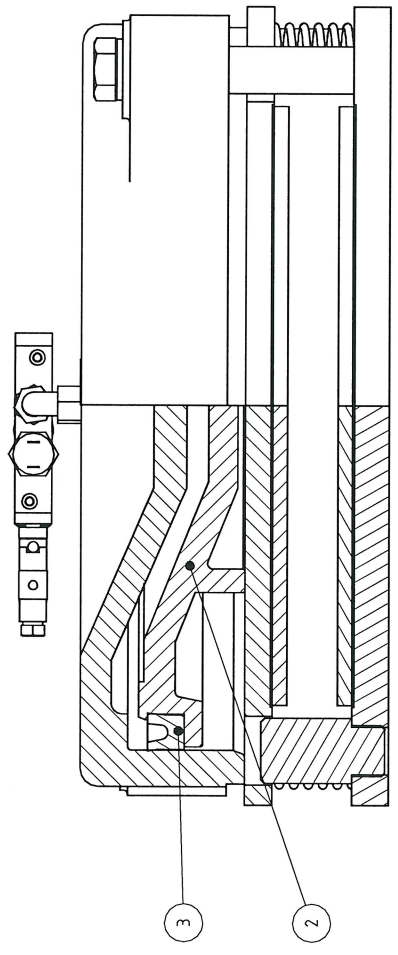

Part list		
Object	Qty	Description
1	1	cylinder
2	1	piston
3	1	grooved ring
4	1	fixed brake pad
5	1	loose brake pad
6	4	distance tube
7	4	hex-head screw
8	4	lock washer
9	1	magnetic valve
11	1	switch
12	4	pressure spring

09. DEZ. 2016

GEPRÜFT / APPROVED
 TÜV SÜD Industrie Service GmbH
 Prüflaboratorium für Produkte der Fördertechnik
 Westendstraße 199
 80635 München
 Sachverständige(r) / Expert

BODE Components		Material:		Gewicht: 110 kg	
Düsseldorf		Rope Brake SB 380			
Allgemeinchteranz DIN ISO 2168 m		Name			
Drehm		SAP/OT/OW			
Geräteart 03.03.16		Stromsteller			
Komponent 03.03.16		Einkaufsnummer:		EU-BD 1018 braking force 28.005N - 44.888N max. rope speed 7m/s	
Einkaufsnummer:		9 6 380 1000		Blatt: 2	
Kundenref: 1000102		Kundenref: 1000102		Blatt: 2	

**EU- Konformitätserklärung für Sicherheitsbauteile für Aufzüge
gemäß EU-Aufzugsrichtlinie 2014/33/EU, Anhang II**

**EU- Declaration of conformity for safety components for lifts
according to the EU Lifts Directive 2014/33/EU, annex II**

CE 0035

Name und Anschrift Hersteller: Name and address Manufacturer:	BODE Components GmbH Eichsfelder Straße 29 40595 Düsseldorf – Deutschland
Beschreibung / Funktion:	Bremseinrichtung auf die Tragseile wirkend als Teil einer Schutzeinrichtung für den aufwärts fahrenden Fahrkorb gegen Übergeschwindigkeit und Bremselament gegen unbeabsichtigte Bewegung des Fahrkorbes
Description / Function	Braking device acting on the suspension ropes, as a part of the protection device against overspeed for the car moving in upwards direction and braking element against unintended car movement.
Typ:	SB-200; SB-330/331; SB-380 Seriennummer und Baujahr: Siehe Typenschild
Type:	SB-200; SB-330/331; SB-380 Serial number and year of manufacture: see type plate
Das Sicherheitsbauteil entspricht: The safety component complies:	EN 81-1:1998+A3:2009 EN 81-2:1998+A3:2009 EN 81-20:2014 EN 81-50:2014
Benannte Stelle der Baumusterprüfung: Notified Body of the type examination:	TÜV Süd Industrie Service GmbH Westendstraße 199 80686 München – Deutschland Kennnummer 0036 Identification No. 0036
Baumusterprüfbescheinigungs Nr.: Type examination no.:	Typ / Type SB-200 - EU-BD 496 Typ / Type SB-330/331 - EU-BD 497 Typ / Type SB-380 - EU-BD 1018
Benannte Stelle der Fertigungsstätten Überwachung: Notified body of the production facilities monitoring	TÜV Rheinland Industrie Service GmbH Am Grauen Stein 51105 Köln – Deutschland Kennnummer 0035 Identification No. 0035
Ort und Datum: Place and Date:	Düsseldorf, 09.12.2016
Bestätigung durch: Confirmation by:	Guntram Hintzsche Geschäftsführer 